

delta

performance

delta performance
ventouse SV/MV

Installation, Operating and Servicing Instructions



excellence in hot water



INTRODUCTION	2	COMMISSIONING	20
Who should read these instructions	2	Filling the hot water and heating circuits	20
Symbols	2	Using the boiler for the first time	20
Applicable standards	2		
Important notes	2	MAINTENANCE	20
		Recommendation	20
DESCRIPTION	3	Boiler maintenance	20
General description	3	Safety equipment maintenance	20
Operating principle	3	Draining the boiler	20
Design characteristics	3		
Boiler views and key to parts	4	USER GUIDE	21
		Use of the boiler	21
TECHNICAL CHARACTERISTICS	5	Setting the burner to safety mode	22
General	5		
Operating condition limits	5	SPARE PARTS	23
Dimensions	5		
Hot water output data	5	SERVICE RECORD	29
General characteristics	5	Details of the installation	29
		Service engineer's report	29
INSTALLATION	6		
Boiler room	6		
Chimney connections	6		
Heating connection	8		
Hot water connection	8		
Control kit	9		
Connection to the gas supply	9		
Electrical connections	10		
BURNER CHARACTERISTICS	12		
Description of the burner	12		
Operating principle of the burner	14		
Control parameters 15 Gas categories	15		
Burner dismantling procedure	16		
Setting procedure in the event of fan replacement 16 Procedure for setting the % of CO ₂	16		
Electrode distance and gap	17		
Burner maintenance	17		
Fault table	18		
Table of corrective measures	19		

INTRODUCTION

WHO SHOULD READ THESE INSTRUCTIONS

These instructions should be read by:

- the specifying engineer
- the installer
- the user
- the service engineer

SYMBOLS

The following symbols are used in these instructions:



Essential instruction for the correct operation of the installation.



Essential instruction for the safety of persons and the environment.



Electric shock hazard.



Burning hazard.

APPLICABLE STANDARDS

The products described in this document have been certified at European level (European Directives 92/42/EEC "Efficiency", 90/396/EEC "Gas Appliance"). They have also be awarded the Belgian label "HR+".



IMPORTANT NOTES

These instructions are an integral part of the equipment to which they relate and must be handed to the user.

The product must be installed and serviced by qualified engineers in accordance with the regulations in force.

ACV declines all liability for any damage caused as a result of incorrect installation or in the event of the use of appliances or accessories that are not specified by ACV.



Failure to follow the instructions describing test operations and procedures may cause injury to persons or a risk of environmental pollution.

N.B.:

ACV reserves the right to change the technical characteristics and specification of its products without notice.

GENERAL DESCRIPTION

- Combined boiler and water heater (*heating and domestic hot water*).
- Hot water generated by the TANK-IN-TANK indirect storage system.
- Equipment required: a water connection kit for the heating circuit supply (*optional*).
- The control panel contains a main switch, a control thermostat for the SV model or potentiometer for the MV model, a thermometer, a Summer/Winter switch and a knockout for the built-in ACV control system (*optional*).
- Delta Performance models SV and MV can be connected as a balanced flue system using a type C concentric or parallel chimney adapter xx, or connected directly to the chimney with a type B23 chimney adapter.
- Delta Performance models SV 35 and 50 have fixed outputs of 35 and 50 kW respectively and are fitted with the ACV BG 2000-SV gas burner.
- Delta Performance models MV 35 and 50 have modulating outputs of 10 to 35 kW and 15 to 50 kW respectively, and are fitted with the ACV BG 2000-MV gas burner.

OPERATING PRINCIPLE

The “Tank-in-Tank” concept

The Delta Performance ventouse range of boilers differs from conventional hot water heaters in that it features a ring-shaped tank which is immersed in the primary water, and which is itself contained in the outer body. The thermostat/potentiometer activates the burner when the heating system or the hot water circuit calls for heat. The combustion gases quickly heat up the primary water and set up a natural circulation around the tank.

Indirect hot water heating

This circulation causes heat to be exchanged between the primary water and the domestic water; heat is exchanged across the entire surface of the tank. Corrugations on the inner and outer shells of the ring-shaped tank further increase the heat exchanger surface, thereby accelerating the water heating process.

Simple to control, safety assured

The temperature of the water in both the heating circuit and the hot water circuit is regulated by a single control. This is achieved by means of the control thermostat or the potentiometer whose bulb is located under the tank in the heating circuit.

A thermal reset high limit thermostat positioned at the top of the boiler automatically cuts out the burner when the temperature of the water in the heating circuit reaches 95°C. A manual reset high limit thermostat locks the burner out if the temperature of the primary water reaches 103°C.

DESIGN CHARACTERISTICS

Outer body

The outer body which holds the primary water is made from STW 22 heavy gauge steel.

“Tank-in-Tank” type storage exchanger

The ring-shaped inner tank is made from 18/10 austenitic stainless steel and features a large heat exchanger surface for rapid hot water heating. It is corrugated over its full height by means of an exclusive production process, and is fully argon welded using the TIG (Tungsten Inert Gas) method.

Combustion gas circuit

The combustion gas circuit is protected by high temperature paint. The circuit comprises:

- Flue ways. The Delta Performance ventouse range has 8 steel flue ways with an inside diameter of 64 mm. Each flue way has baffles made of special steel designed to improve the heat exchange and reduce the flue gas outlet temperature.
- Sealed combustion chamber. The combustion chamber is water-cooled.

Insulation

The boiler body has full sprayed-on rigid polyurethane foam insulation with a high insulation coefficient. No CFC emissions are created by the spraying process.

Casing

The boiler is covered with a steel casing that has been stove enamelled at 220°C after scouring and phosphating.

DESCRIPTION

BOILER VIEWS AND KEY TO PARTS

1. Control panel
2. Detachable casing cover (access to baffles)
3. Chimney reducing pipe
4. Measuring unit with condensate trap (optional)
5. Polyurethane foam insulation
6. Outer body containing the primary water
7. Side casing
8. Base
9. Burner cover
10. Burner chamber plate
11. Control thermostat bulb (model SV)
Potentiometer bulb (model MV)
12. Detachable front panel
13. Air supply pipe to venturi
14. Manual reset high limit thermostat (103°C)
15. Bulb of the thermal reset high limit thermostat (95°C)
16. Balanced flue adapter
17. Heating return
18. Cold water inlet
19. Inner annular tank containing hot water
20. Combustion chamber
21. Boiler drain cock
22. Heating return
23. Flue ways
24. Baffles
25. Hot water outlet
26. Heating out

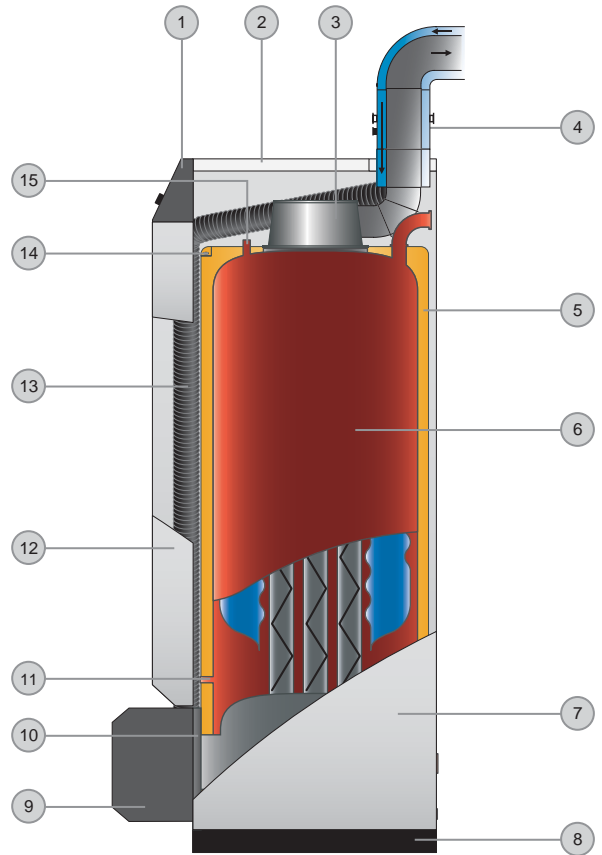

Fig. 1: Right-hand side view of boiler

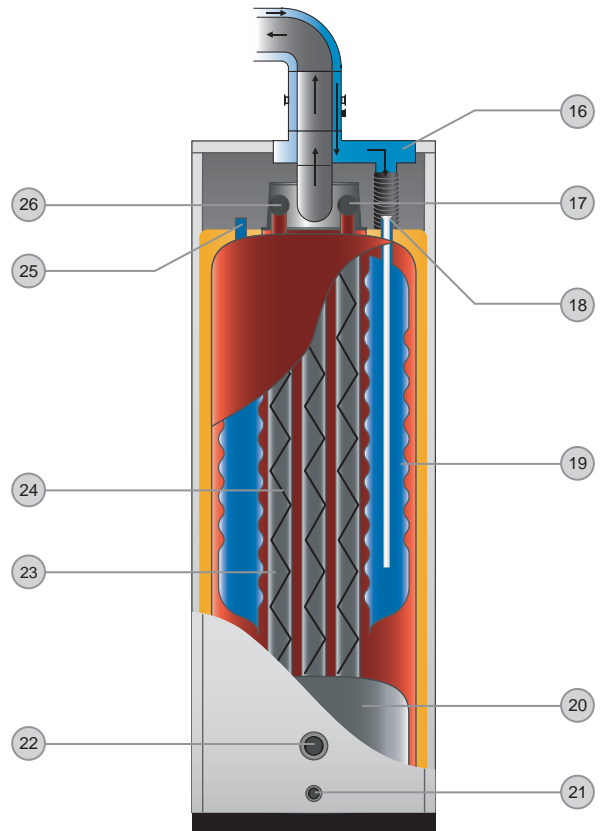

Fig. 2: Rear view of boiler

GENERAL

The appliances are supplied fully assembled, tested and packed standing on a timber base with impact protection strips and wrapped in heat-shrunk plastic film. When the appliance arrives, remove the packaging and check that no parts have been damaged in transit. Refer to the dimensions and weights listed below for handling purposes:

OPERATING CONDITION LIMITS

Maximum service pressure (tank filled with water)

- Heating circuit: 3 bar
- Hot water circuit: 10 bar

Test pressure (tank filled with water)

- Heating circuit: 4.5 bar
- Hot water circuit: 13 bar

Operating temperature

- Maximum temperature: 90 °C

Water quality

- Chlorides: < 150 mg/l (304 stainless steel)
< 2000 mg/l (Duplex)
- 6 □ pH □ 8

DIMENSIONS

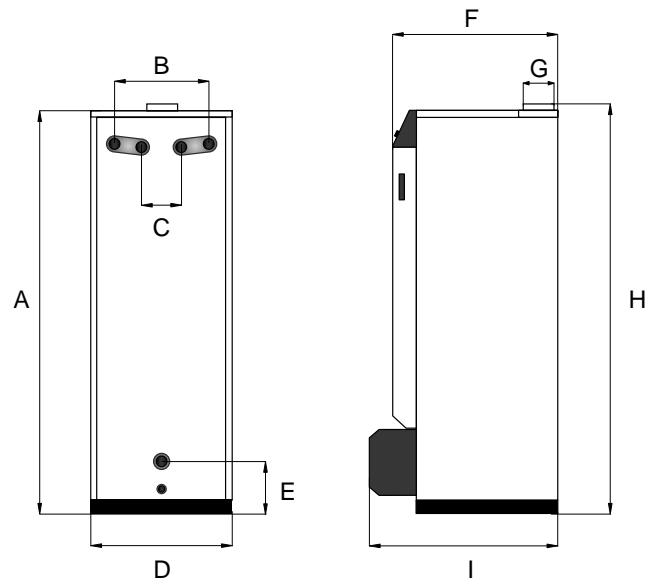

	A mm	B mm	C mm	D mm	E mm	F mm	G mm	H mm	I mm	kg (*)
Delta Performance SV/35	1585	390	200	542	125	645	80/80/125	1610	800	182
Delta Performance SV/50	1830	390	200	542	125	645	100/100/150	1880	800	220
Delta Performance MV/35	1585	390	200	542	125	645	80/80/125	1610	800	182
Delta Performance MV/50	1830	390	200	542	125	645	100/100/150	1880	800	220

(*) The weights shown are drained weights.

HOT WATER OUTPUT DATA

		SV/35	SV/50	MV/35	MV/50
• Operating conditions at 80°C					
Peak flow at 40°C (ΔT = 30°C)	I/10'	291	328	291	328
Peak flow at 40°C (ΔT = 30°C)	I/60'	1044	1393	1044	1393
Constant flow at 40°C (ΔT = 30°C)	I/h	920	1352	920	1352
• Tank refill time at 60°C					
Initial heating time	minutes	20	13	20	13
After drawoff of 140 l at 45°C	minutes	10	8	10	8

GENERAL CHARACTERISTICS

		SV/35	SV/50	MV/35	MV/50
Input	kW	34.9	50	10 / 34.9	15 / 50
Output	kW	32	46.7	9.5 / 32	14.5 / 46.7
Maintenance loss (60°C)	%	0.5	0.5	0.5	0.5
Total capacity	l	127	162	127	162
Heating circuit capacity	l	62	82	62	82
Heating connection	Ø	1"	1"	1"	1"
Hot water connection	Ø	3/4"	3/4"	3/4"	3/4"
Water tank heat exchanger surface	m ²	1.99	2.46	1.99	2.46
Combustion efficiency	%	92.9	93.5	96.4 / 92.9	97 / 93.5
Average CO ₂	%	9	9	9	9
Mass flow rate of combustion products	g/sec.	16.1	23	4.6 / 16.1	23

INSTALLATION

BOILER ROOM

Important

- Never obstruct the ventilation.
- Do not store inflammable products in the boiler room.
- Avoid storing corrosive products such as paint, solvents, chlorine, salt, soap or other cleaning products near the boiler.

Accessibility

The boiler room should be big enough to allow easy access to the boiler. Minimum clearances around the boiler (mm):

- to the front 500
- to the rear 150
- to the sides 100
- above 700

Ventilation

The boiler room must have both low and high level ventilation (see Fig. 3).

By way of information, the table below gives the minimum ventilation requirements according to Belgian regulations.

The user must ensure that his boiler room ventilation complies with local regulations.

		SV - MV / 35	SV - MV / 50
Ventilation			
Fresh air supply min.	m ³ /h	63	90
High level ventilation (A)	dm ²	1.5	1.5
Low level ventilation (B)	dm ²	1.5	2
Draught stabiliser (C)	∅	80	100

N.B.:

The figures for (B) and (C) only apply to type B23 connectors.

Base

The base on which the boiler will be mounted must be made from non-combustible materials.

CHIMNEY CONNECTIONS



IMPORTANT

The boiler must be installed by a qualified engineer in accordance with the local standards and codes of practice.



The diameter of the chimney must not be less than the diameter of the boiler's chimney reducer.

Chimney connector type: B23 (Fig.3)

The chimney must be connected to the boiler by means of a metal pipe rising at an angle from the boiler to the chimney.

A chimney connection is required.

- A. High level ventilation
- B. Low level ventilation
- C. Draught stabiliser
- D. Flame inspection window
- E. Height of lined chimney
- F. Chimney diameter

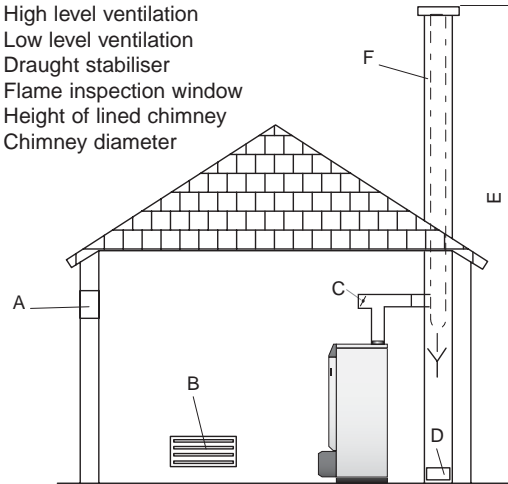

Fig. 3: Boiler ventilation and chimney connection type B23

		SV - MV / 35	SV - MV / 50
Chimney			
E = 5 m ∅ min. F	mm	213	236
E = 10 m ∅ min. F	mm	179	199
E = 15 m ∅ min. F	mm	162	179



Important note:

The above table is shown by way of indication only as regulations vary from country to country.



The high efficiency of our boilers means that the flue gases exit at low temperature. The attendant risk of condensation may cause damage to some chimneys. To avoid this risk we strongly advise that you line the chimney.

Please contact your installer for further information about chimney lining.

CHIMNEY CONNECTORS TYPE: C XX (Figs. 4, 5 and 6)

- C 13 (x): Concentric / parallel connector with horizontal terminal.
- C 33 (x): Concentric / parallel connector with vertical terminal.
- C 43 (x): Concentric / parallel connector for several boilers in a common chimney.
- C 53 (x): Parallel chimney connector with air intake and flue gas outlet in different pressure zones (different locations).
- C 63 (x): Connector for connection to an approved discharge system (Netherlands, Germany and Luxembourg only).

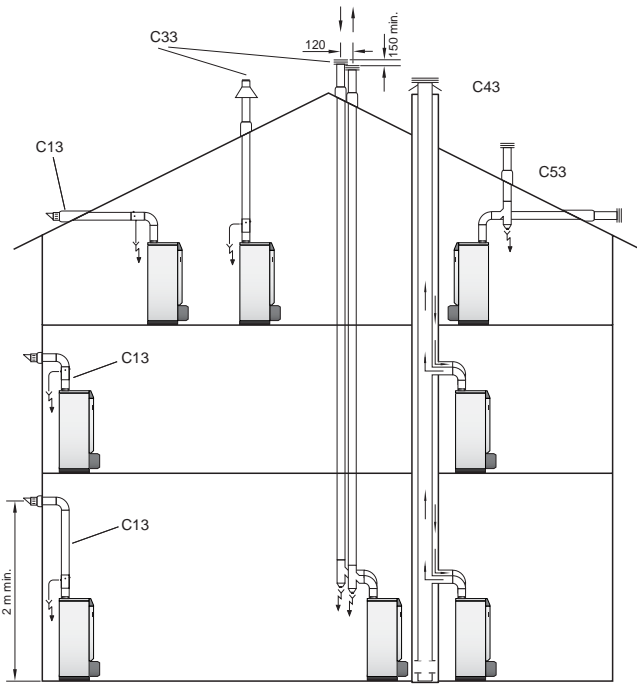

Fig. 4: Chimney connectors type C xx



Fig. 5:
Concentric connector



Fig. 6:
Parallel connector



A condensation drain outlet must be fitted close to the boiler to prevent condensation products from the chimney running into the boiler.

Concentric connector

Maximum length concentric tubing:
6 metres due to the maximum air temperature at the venturi (70°C).

Note:

- A 90 degree bend = 1 metre equivalent length.

Example:

- 6 metres concentric = one 90° bend + 4 metres horizontal + outlet 1 metres.

“CE” approved according to EN 483



A drain outlet must be provided near the boiler to prevent condensation from the chimney entering the boiler.



All horizontal pipe runs must fall to the boiler to prevent condensation water escaping from the terminal.

Parallel connector

Table of flue resistance in Pascal (max. 100 Pa)
(1 Pascal = 0,01 mbar)

	SV - MV / 35 Ø 80 mm	SV - MV 50 Ø 100 mm
Straight pipe L. 500 mm	1.18	1.82
Straight pipe L. 1000 mm	2.55	2.3
Straight pipe L. 2000 mm	5.1	4.6
90° pipe bend	4.32	6
45° pipe bend	2.75	3.1
30° pipe bend	1.67	1.7
5° pipe bend	0.69	0.76
Vertical terminal	5.4	3.53
Horizontal terminal	5.5	3.53
Condensation drain	2.06	1.53

This table is based on the equipment offered by ACV and cannot be applied generally.

Sample calculation

The diagram below consists of the following parts (Ø 80 mm) :

- 1 x Pipe bend 90°
- 2 x Straight pipe L 2000 mm
- 2 x Pipe bend 45°
- 2 x Straight pipe L 1000 mm
- 1 x Vertical terminal
- 1 x Condensation drain vertical

Calculation:

- 1 x 4,32 = 4,32
- 2 x 5,1 = 10,2
- 2 x 2,75 = 5,50
- 2 x 2,55 = 5,10
- 1 x 5,4 = 5,4
- 1 x 2,06 = 2,06

Total: 32,58 x 2 = 65,16 Pa

This value is less than the maximum authorised resistance, therefore the installation is compliant.

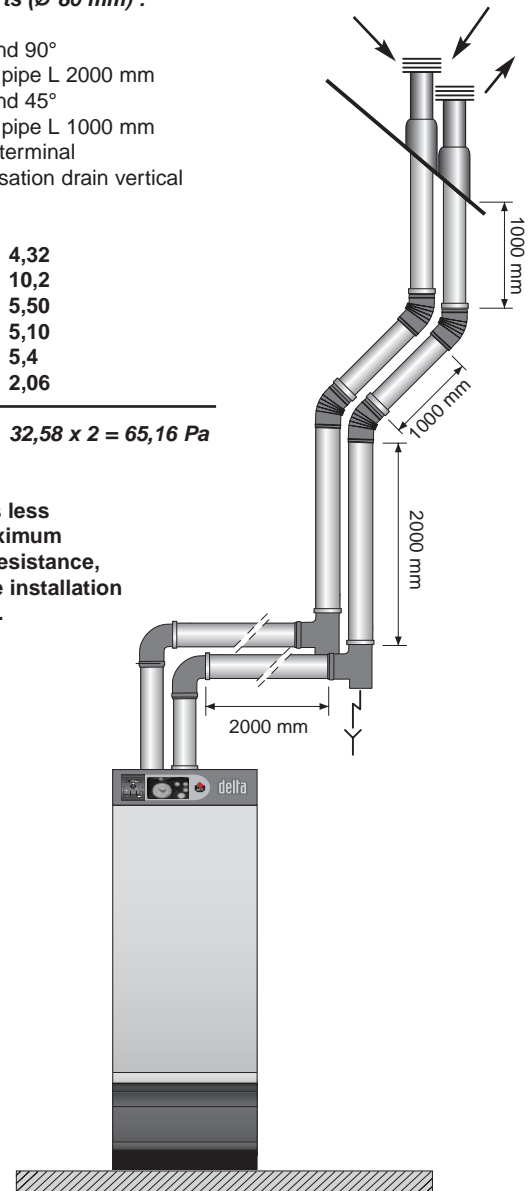

INSTALLATION

CONNECTING THE HEATING SYSTEM

ACV kit water

ACV can supply an optional pre-assembled water kit. This kit comprises:

- A pump;
- A 3-way manual valve. This valve can be motorised if required;
- Connection pipes that can be used to connect a second heating circuit;
- Two isolating valves;
- Connectors for the right or left hand mounting of the expansion vessel, the safety valve with pressure gauge and the filling valve. (The expansion vessel is not included).



fig. 7 : ACV water kit

Typical single circuit configuration

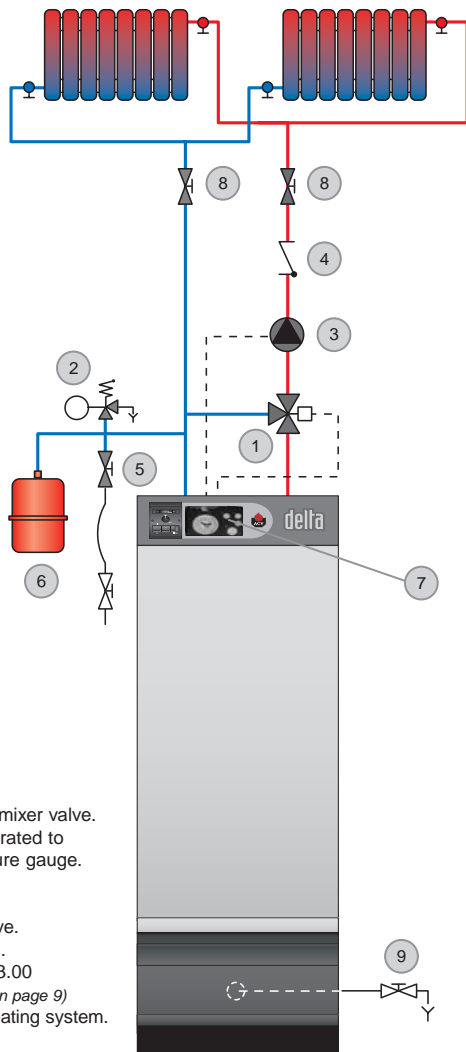

Fig. 8: Heating system layout

1. 3-way motorised mixer valve.
2. Safety valve calibrated to 3 bar, with pressure gauge.
3. Pump.
4. Non-return valve.
5. System filling valve.
6. Expansion vessel.
7. Controller ACV 13.00 (see Controller Kit on page 9)
8. Isolating valve, heating system.
9. Drain cock.

Drain

The drain cock and safety valve must be connected to the building drain.

HOT WATER CONNECTION

Pressure reducing valve

If the mains water pressure exceeds 6 bar, a pressure reducing valve calibrated to 4.5 bar must be installed.

Safety group

The safety group of the water tank must be approved by ACV and calibrated to 7 bar; the group's valve discharge must be connected to the drain.

Hot water expansion vessel

Installing a hot water expansion vessel will prevent any risk of excess pressure due to water hammer or pressure fluctuations.

Hot water circulation

If the water tank is a long way from the point of use, installing a closed recirculation circuit can ensure a faster hot water drawoff at any time.

Typical circuit with thermostat valve

1. Safety group
2. Pressure reducing valve
3. Thermostatic mixer
4. Hot water pump
5. Non-return valve
6. Hot water expansion vessel
7. Cold water supply tap
8. Drawoff tap
9. Drain cock
10. Air vent
11. Isolating valve

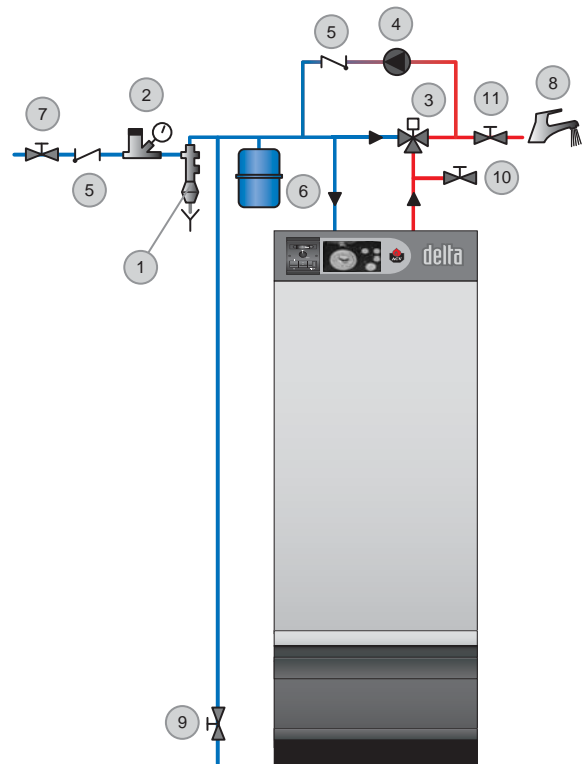

Fig. 9: Hot water system layout



IMPORTANT

As a safety measure, we strongly advise the installation of a thermostatic mixer to prevent any risk of burning to persons.

Optional accessories

Safety group	Ø 3/4"
Pressure reducing valve	Ø 3/4"
Thermostatic mixer	Ø 3/4"
Expansion vessel	5 litres

CONTROLLER KITS

KIT 1: ACV 13.00 / Basic

This basic kit is used to control the hot water circuit outlet temperature as a function of ambient conditions.

It comprises: a temperature controller with analog clock, a surface-mounted primary water temperature sensor (-30/130°C), an outdoor sensor (-30/50°C), a servomotor SSSY 319 230 V - 3-pin and an intermediate socket.



KIT 2: ACV 13.00 / Standard

This basic kit is used to control the hot water circuit outlet temperature as a function of ambient conditions.

It comprises: a temperature controller with analog clock, a surface-mounted primary water temperature sensor (-30/130°C), an outdoor sensor (-30/50°C), a servomotor SQY 349 230 V - 3-pin and an intermediate socket.



Circuit diagram of ACV control kits

- B2. Temperature sensor
- B9. Outdoor sensor
- B5. Analog/digital room sensor
- P1. Pump
- Y1/Y2/N. Servomotor (SSY 319 or SQK 349)
 - bl. Blue N
 - n/z. Black Y2
 - br. Brown Y1

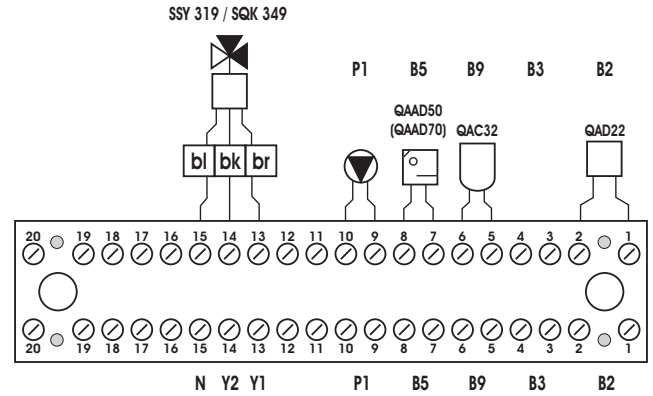

Please contact your installer for further details about this.

CONNECTION TO THE GAS SUPPLY



- The boiler is fitted with a 3/4" M connector, to which you can connect the gas tap.
- You must comply with the NBN D51-003 standard for connections to the gas and, if applicable, with the other standards in force in the location of the connection.
- Where there is a risk of dirt stemming from the network, place a gas filter upstream from the connection.
- Drain the gas pipe and check in minute detail that all the boiler pipes, both inside and outside, are sealed.
- Check the gas pressure in the system.
- Check the gas pressure and consumption when commissioning the appliance.

INSTALLATION

ELECTRICAL CONNECTIONS

Principle of supply

The boiler operates on a single-phase supply of 230 V/50 Hz. You should install a control box with main switch and 6 A fuses externally to the boiler to allow the boiler to be isolated from the supply for servicing and repairs.

Statutory compliance

The installation must comply with your local standards and codes of practice.

Safety

The stainless steel water tank must be provided with a separate earth.



The boiler must be isolated from the electrical supply before any work is carried out on it.

Wiring for the SV boiler (Fig. 10)

1. Control thermostat (60/90°C)
2. Thermal reset high limit thermostat (95°C)
3. Manual reset high limit thermostat (103°C max.)
4. Main switch
5. Reset
6. Burner shutdown indicator lamp
7. Summer/Winter switch
8. Power supply to boiler
9. Room thermostat (optional)
10. Heating pump connection
11. Boiler electrical supply connection (6-pin plug)
12. Burner connection (7-pin plug)

Wiring for the MV boiler (Fig. 11)

1. Potentiometer (60/90°C)
2. Thermal reset high limit thermostat (95°C)
3. Manual reset high limit thermostat (103°C max.)
4. Main switch
5. Reset
6. Burner shutdown indicator lamp
7. Summer/Winter switch
8. Power supply to boiler
9. Room thermostat (optional)
10. Heating pump connection
11. Boiler electrical supply connection (6-pin plug)
12. Burner connection (6-pin plug)
13. Fan connection (PWM and 230 V)
14. NTC sensor
15. Printed circuit board
16. Control/monitoring relay

Key to wiring

- B. Blue
- Bk. Black
- Br. Brown
- G. Grey
- Gr. Green
- Or. Orange
- R. Red
- W. White
- Y. Yellow
- Y/Gr. Yellow / Green

Delta performance SV (Fig. 10)

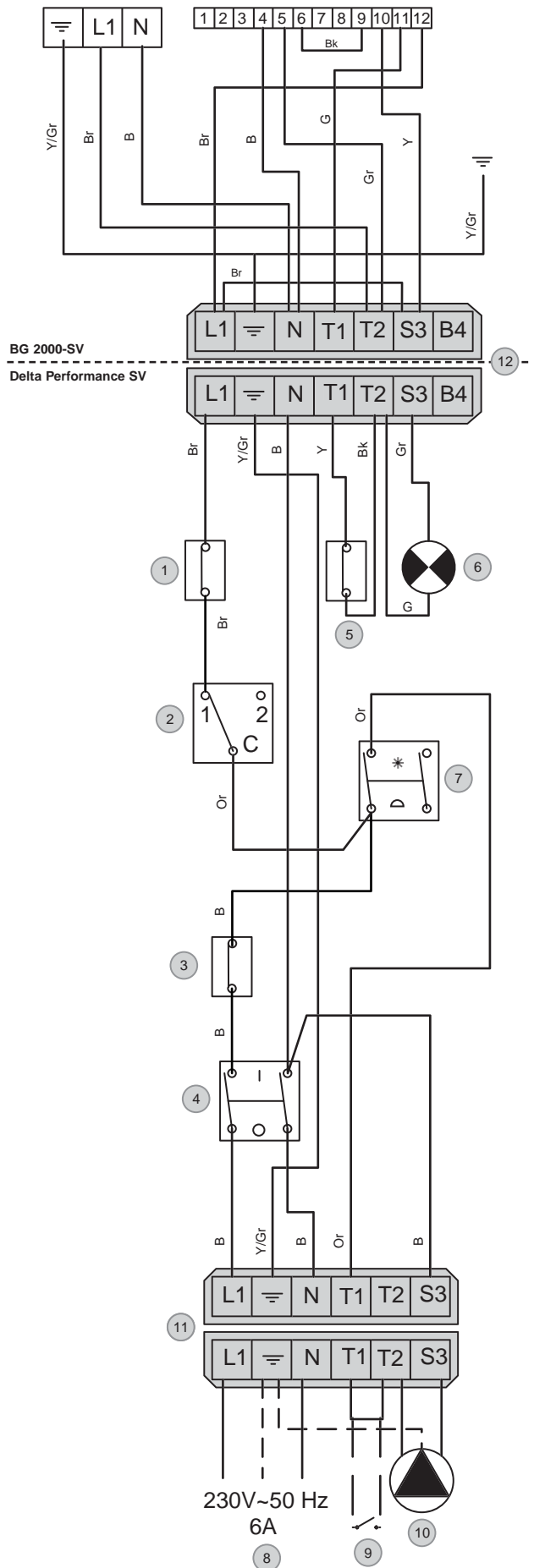

Delta performance SV (Fig. 11)

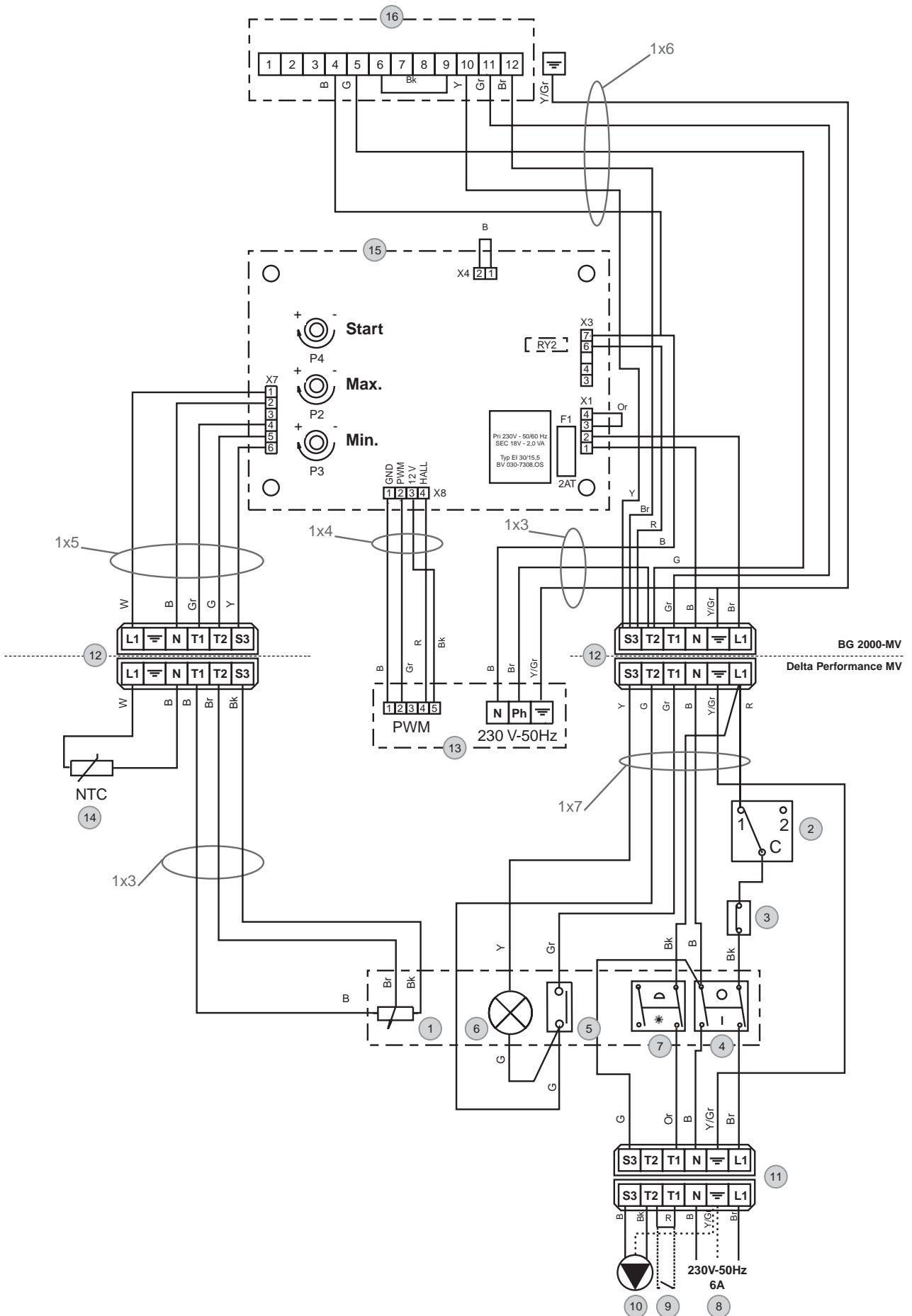

BURNER CHARACTERISTICS

DESCRIPTION OF THE BURNER

Gas burner ACV BG 2000-SV

ACV BG 2000 air/gas premix burners are equipped with a gas valve, a venturi and a Honeywell electrical control relay. These items have been specially developed for low NOx air/gas premix burners with automatic ignition and flame detection.

Gas burner ACV BG 2000-MV

The ACV BG 2000-MV burner is based on the technology of the ACV BG 2000-SV burner but offers the benefits of a modulating burner. The burner's output is constantly adjusted to suit the fluctuating demand for heat, thus optimising operating efficiency.



BG 2000-SV and MV burners are preset in our factory for use with natural gas (equivalent to G20).

CONVERSION TO PROPANE: (refer to the conversion instructions)



Prohibited in Belgium.

Conversion kit supplied with the boiler comprises:

- Orifice(s).
- Propane rating plate(s).
- Self-adhesive settings label.
- Conversion instructions.

BURNER BG 2000-SV AND MV

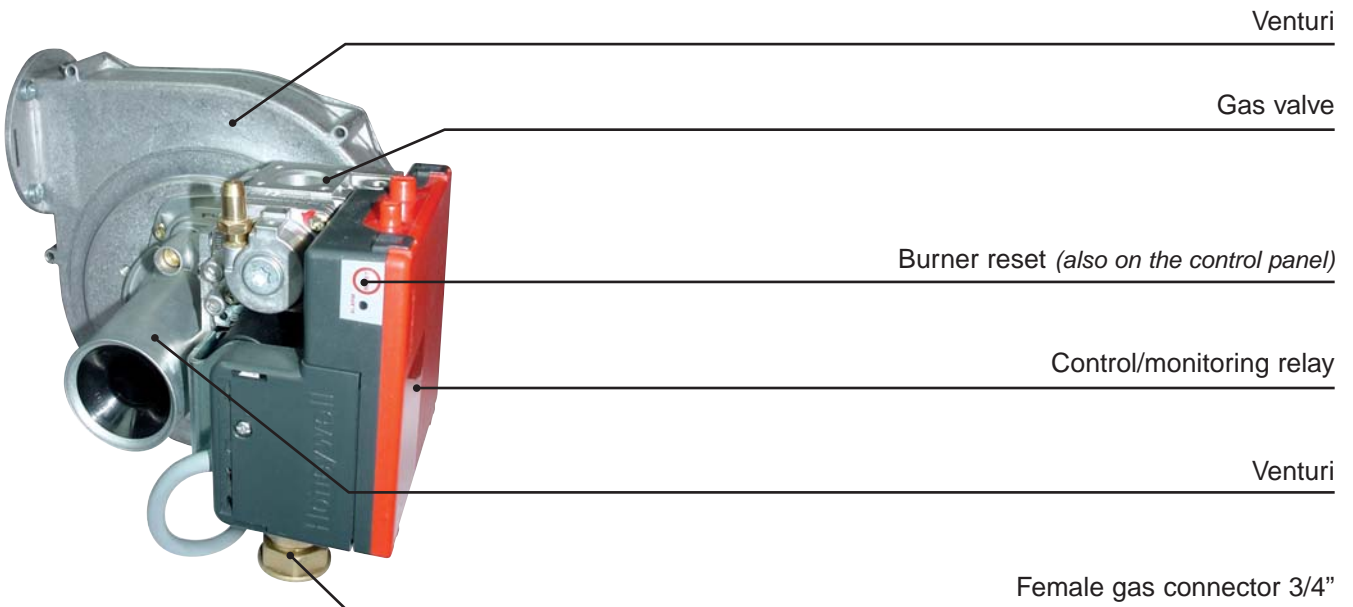

Burner chamber plate insulation

Ignition electrode

NIT burner tube

Ionisation electrode

Burner chamber plate sealing cord

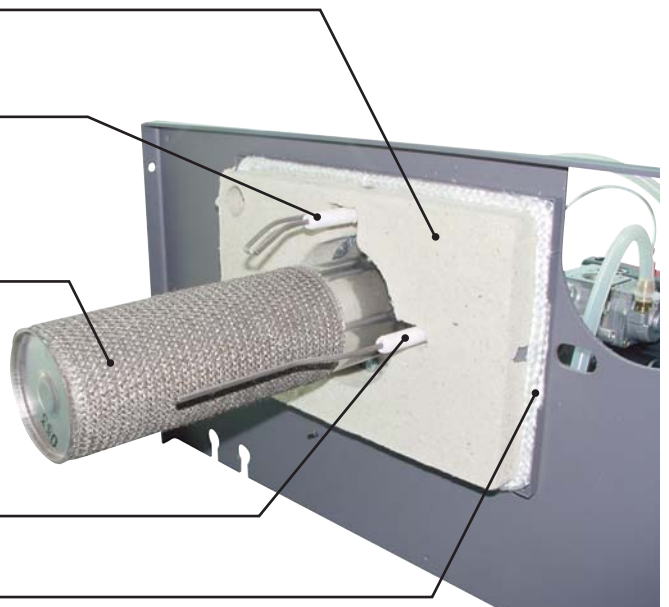

BURNER BG 2000-SV

Burner chamber plate

Flame inspection window

Ignition cable

Ionisation cable

Control/monitoring relay

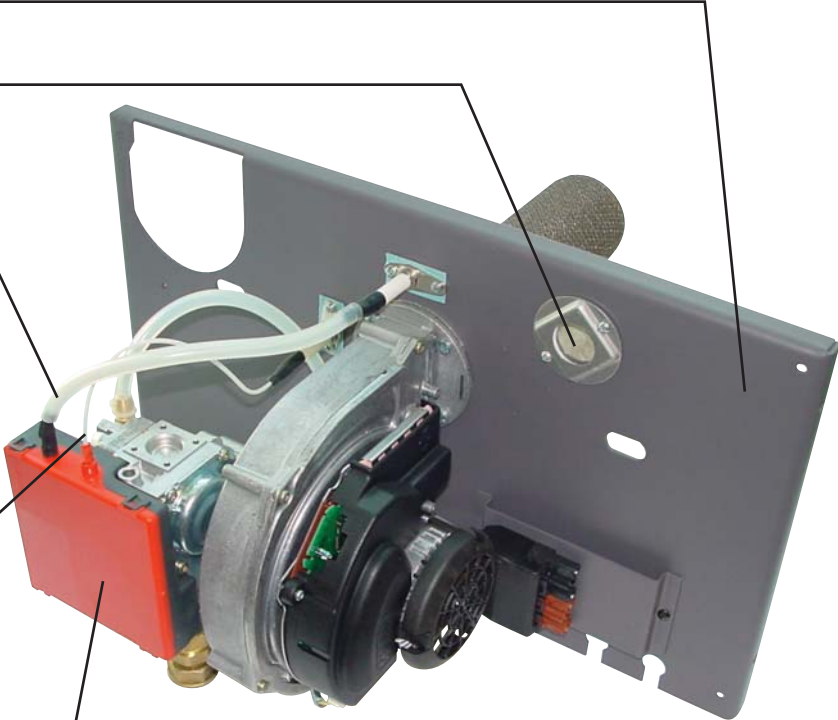

BURNER BG 2000-MV

Burner chamber plate

Flame inspection window

Box containing the p.c.b.

Ignition cable

Control/monitoring relay

Ionisation cable

PWM connector

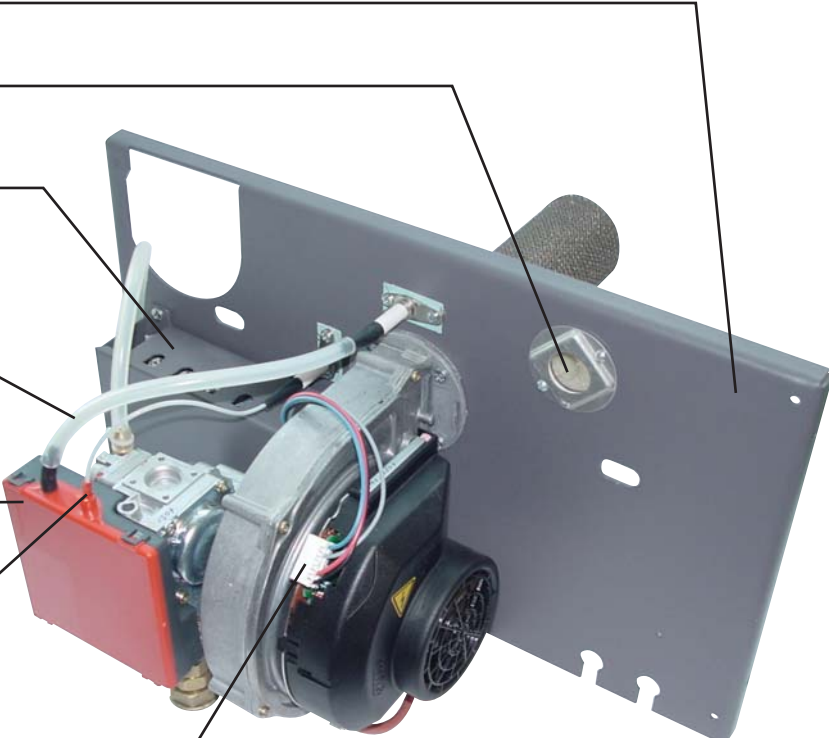

BURNER CHARACTERISTICS

OPERATING PRINCIPLE OF THE BURNER

AIR/GAS mixture control (Fig. 12)

The fan draws air in across the venturi. This creates a vacuum **P1** at the venturi neck. The gas valve regulator now reacts to maintain a difference equal to the amount of the offset between the pressure at the gas valve outlet **P2** and atmospheric pressure **P3**: **P2 – P3 = offset**.

If the air flow decreases, **P1** rises; the same applies to **P2**; now **P2 > P3**; the regulator **R** moves upwards and restores the equilibrium **P2 – offset = P3**; pressure **P4** falls and valve **C** moves down: the gas flow decreases.

Whatever the speed of the fan therefore, the Air/Gas ratio is maintained equal to 1 to within the amount of the offset.

The difference in pressure between the neck of the venturi and the outlet from the gas valve now draws gas through the venturi.

The gas flow adjuster screw is used to adjust the amount of gas that is to be injected for a given air flow, and this will determine the %CO₂ in the flue gas. It is now a very simple matter to control the burner's power by adjusting the fan speed and the %CO₂ to predefined settings.

Ignition and flame monitoring

The control and monitoring relay has a dual function: it ignites the burner by producing sparks at the ignition electrode, and it monitors the actual presence of a flame when the gas valve is open (it measures the ionisation current).

Starting sequence: (Fig. 13)

The fan starts up when the boiler thermostat/potentiometer detects a demand for heat. After a 15 second pre-purge the gas valve opens simultaneously with the ignition. Provided an ionisation current is detected inside the first 5 seconds, combustion continues normally until heat is no longer called for. Otherwise, the gas valve closes and the fan stops; the burner is now shut down.

If the burner shuts down:

1. The burner indicator lamp lights up on the control panel and on the burner.
2. Press the burner reset button on the control panel. Turn the boiler off for several seconds at the main switch, then restart the the boiler.

Gas tube (Fig. 14)

The air/gas mixture leaving the gas valve/venturi assembly is propelled into the burner tube.

This tube is covered with metal fibres (NIT). This enhances the distribution of the flame, increasing its life and significantly reducing pollutant emissions.

Combustion of the air/gas mixture is also spread uniformly around the circumference of the tube. The tube is also designed to withstand propane combustion.

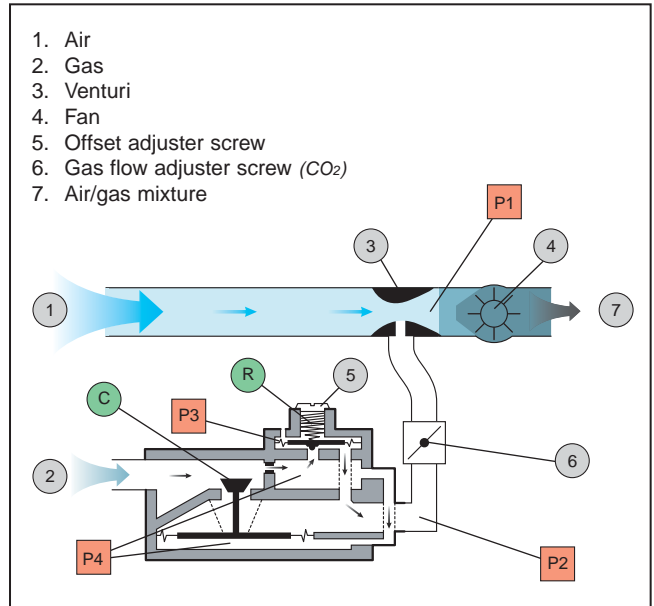

Fig. 12: Air/gas mixture control

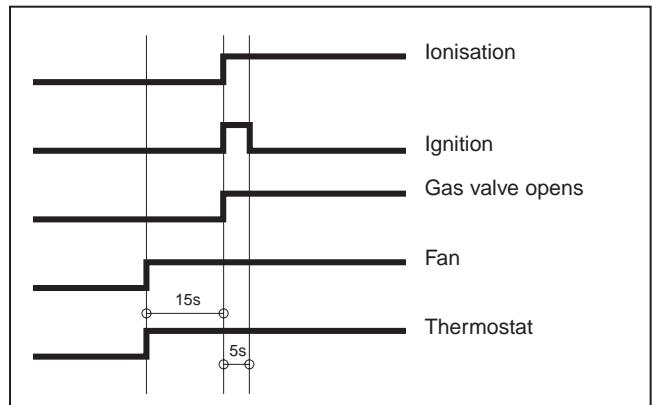

Fig. 13: Starting sequence

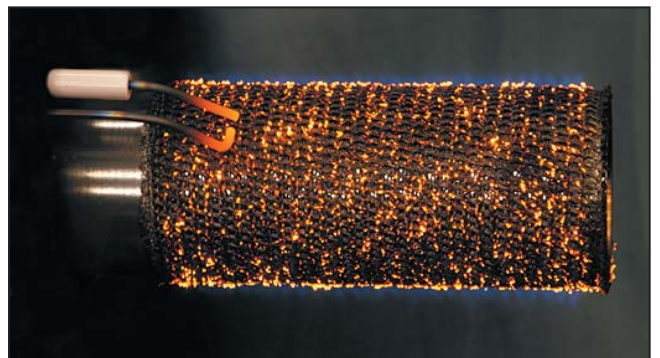

Fig. 14: The NIT gas tube in operation

BURNER CHARACTERISTICS

SETTING PARAMETERS

TYPE		SV/35	SV/50	MV/35	MV/50
Input	kW	34.9	50	10 / 34.9	15 / 50
Nominal output	kW	32	46.7	9.5 / 32	14.5 / 46.7
Combustion efficiency - natural gas	%	92.9	93.5	96.4 / 92.9	97 / 93.5
Offset	mbar	0	0	- 0.4	- 0.4
Starting speed	r.p.m.	-	-	4000	4000
Min. speed	r.p.m.	-	-	1370	1400
Max. speed	r.p.m.	4600	4400	4600	4400
CO ₂ natural gas	%	9	9	9	9
CO ₂ propane	%	11.0 / 11.2	11.0 / 11.2	11.0 / 11.2	11.0 / 11.2
Gas G20 - 20 mbar - I 2E(S)B - I 2Er - I 2H - I 2ELL - I 2E					
Flow	m³/h	3.7	5.3	1.06 / 3.7	1.6 / 5.3
Gas G25 - 20 mbar - I 2ELL / 25 mbar - I 2L					
Flow	m³/h	4.31	6.15	1.24 / 4.31	1.85 / 6.15
Gas G31 - 30/37/50 mbar - I 3P					
Flow	m³/h	1.43	2.05	0.41 / 1.43	0.61 / 2.05
Burner chamber pressure	mbar	0.2	0.2	0.2	0.2
Net T° of combusted gases	°C	140	140	80 / 140	60 / 140

N.B.:

- The burners are preset in our factory for use with natural gas (*equivalent to G20*)
- An adjustment of the CO₂ % is not allowed in Belgium. I 2E(S)B

GAS CATEGORIES

	BE	FR	AT	DK	ES	UK	IT	PT	IE	SE	NL	LU	DE
I 2Er		X											
I 2E(S)B	X												
I 2H			X	X	X	X	X	X	X	X			
I 3P	X	X			X	X		X	X				
I 2L											X		
I 2ELL													X
I 2E												X	

BURNER CHARACTERISTICS

BURNER DISMANTLING PROCEDURE



For safety reasons it is essential that you isolate the power supply and the gas supply valve before carrying out any work on the burner.

Dismantling the burner

1. Remove the burner cover.
2. Disconnect the gas connector and the electrical plugs of the burner.
3. Disconnect the air supply pipe from the venturi.
4. Take off the burner chamber plate by undoing the two retaining nuts.

Burner re-assembly

The burner is re-assembled in the reverse order of dismantling (Step 4 to Step 1).

SETUP PROCEDURE IN THE EVENT OF FAN REPLACEMENT

Fan speed for burner BG 2000-SV: (Fig. 15)

- Remove the green plug on the front of the fan to gain access to the adjuster screw on the potentiometer (A).



Fig. 15

- Measure the speed of the impeller that is mounted on the motor shaft. Adjust the speed of the fan according to the parameters (Start, Min., Max.) listed in the table of setting parameters on Page 15 by turning the potentiometer screw (counter-clockwise to reduce the fan speed and clockwise to increase it).

Fan speed for burner BG 2000-MV:

If the fan of a BG 2000-MV burner is replaced, the fan's speed is controlled directly by the PWM connector which connects the fan to the p.c.b.



The potentiometers on the p.c.b. (Start, Min. and Max.) must be adjusted by an engineer approved by ACV.

PROCEDURE FOR SETTING THE % OF CO₂

- Measure the burner combustion with an electronic flue gas analyser.
- Adjust the % of CO₂ to the figure shown in the table of setting parameters on Page 15 by turning the gas flow adjuster screw on the gas valve. (Fig. 16)

Turn counter-clockwise (more gas) ⇒ increases the % of CO₂.
Turn clockwise (less gas) ⇒ reduces the % of CO₂.



The offset (4) is set at the factory and requires no adjustment. Nevertheless ACV recommends that you check this setting. (Refer to the table of setting parameters). You should contact your installer should you find any significant deviation.

1. Gas flow adjuster screw
2. Offset pressure measuring point
3. Upstream gas pressure measuring point
4. Offset adjuster screw cover

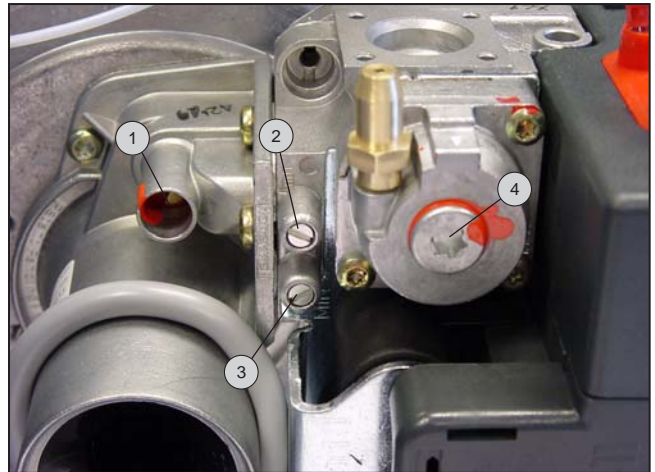

Fig. 16

ELECTRODE DISTANCE AND GAP

- Distance between ionisation electrode and tube:
X = 10 to 15 mm (refer to Fig. 17)
- Distance between ignition electrode and tube:
Y = 4 to 7 mm (refer to Fig. 18)
- Ignition electrode gap:
Z = 2 to 5 mm (refer to Fig. 19)



Fig. 17

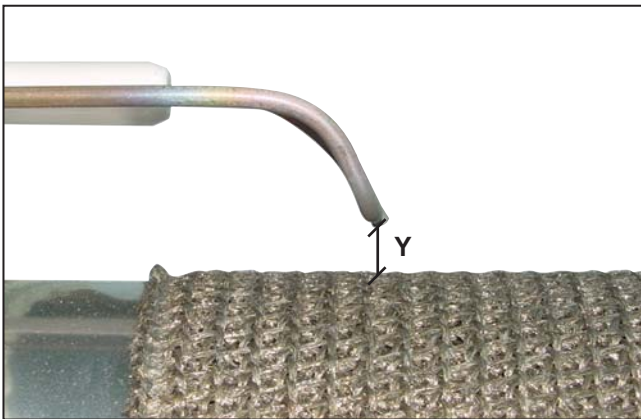

Fig. 18

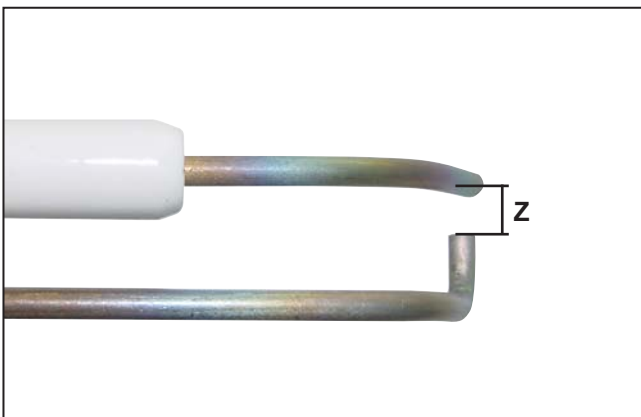

Fig. 19

BURNER MAINTENANCE (refer to Fig. 20)

1. After dismantling the burner, check the condition of the ignition electrode (1) and ionisation electrode (2), the insulation (3) and the burner chamber plate seal (4). Replace these items if necessary.
2. Check the condition of the tube (5).
3. Re-assemble the burner and check burner ignition.
4. Check the gas connection for leaks.
5. Check the combustion parameters.

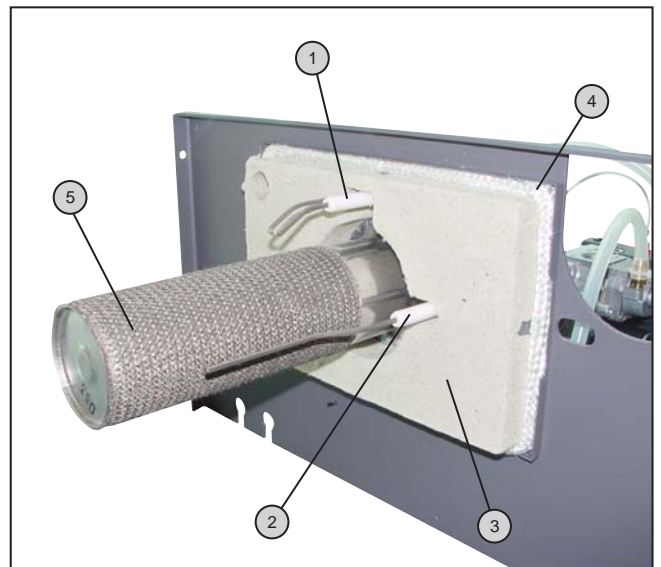

Fig. 20

BURNER CHARACTERISTICS

FAULT TABLE

Corrective measures										
Problems										
Condensation in the chimney:										
Smell of flue gas:										
Insufficient heating:										
The burner switches to safety mode after lighting:										
Noisy pump:										
Not enough hot water:										
Pump not running:										
Burner fails to light:										
The manual reset high limit thermostat is tripped:										
Reasons										
Chimney is cold and/or not lined									x	1
Boiler T° is set too low			x			x			x	2
Chimney blocked									x	3
Combustion spillage in the chimney:									x	4
Insufficient or no ventilation in the boiler room									x	5
Boiler clogged			x			x			x	6
Burner clogged			x		x	x			x	7
Room thermostat T° set too low									x	8
Pump jammed or faulty			x						x	9
Boiler switch is in the Summer position or is faulty	x	x							x	10
Insufficient water in the system«	x	x	x	x					x	11
Radiator valves closed									x	12
System not vented properly				x	x				x	13
Low gas pressure				x		x			x	14
Gas pipe too small				x		x			x	15
Boiler thermostat/potentiometer faulty	x		x						x	16
The electrical system is not earthed (<i>properly</i>)	x								x	17
System fuses have blown	x	x							x	18
System and/or boiler not vented properly	x		x	x					x	19
Not enough time allowed between large drawoffs				x						20
Drawoff flow too fast				x						21
Room thermostat faulty or not turned on			x						x	22
Faulty Summer/Winter switch	x	x	x						x	23
Main switch is faulty or not turned on	x	x	x						x	24
Faulty NTC sensor	x		x						x	25
Thermal reset high limit thermostat (95°C) activated	x									26
Manual reset high limit thermostat (103°C) activated	x									27
Faulty printed circuit board	x									28
P.c.b. fuse blown	x									29
Faulty burner fan	x									30
No PWM signal	x									31
Ignition electrode faulty or incorrectly set	x									32
Ionisation electrode faulty or incorrectly set	x									33
Burner connectors not inserted properly	x									34
Blocked gas valve	x									35
Faulty p.c.b. relay	x									36
Boiler thermostat/potentiometer faulty	x									37
Top of boiler not vented properly	x									38
NTC sensor incorrectly inserted in its pocket	x									39

TABLE OF CORRECTIVE MEASURES

Corrective measures	
Fit lining in the chimney	1
Increase the boiler T°	2
Check and clean the chimney	3
Check and clean the chimney	4
Comply with local requirements governing boiler room ventilation	5
Clean the burner and the boiler	6
Clean the burner and the boiler	7
Set the room thermostat to the required temperature	8
Free the pump or replace it	9
Move the switch to the Winter position or replace it	10
Properly fill and vent the system and the boiler	11
Open the radiator taps or adjust the thermostat valves	12
Properly fill and vent the system and the boiler	13
Check that the pipes and the meter are suitable for the system	14
Check that the pipes and the meter are suitable for the system	15
Replace the boiler thermostat/potentiometer	16
Ensure that the electrical system complies with regulations	17
Replace the fuses and look for the cause of the problem	18
Properly fill and vent the system and the boiler	19
Adhere to the performance data as indicated by ACV	20
Adhere to the performance data as indicated by ACV	21
Set the thermostat to the required temperature or replace it	22
Replace the Summer/Winter switch	23
Replace the main switch	24
Replace the NTC sensor	25
Replace the boiler thermostat/potentiometer	26
Abnormal situation	27
Replace the p.c.b.	28
Replace the p.c.b. but look for the cause of the malfunction	29
Replace the fan	30
Replace the p.c.b. if the fan turns but does not send a PWM signal	31
Replace the electrode or set it correctly	32
Replace the electrode or set it correctly	33
Insert the connectors correctly	34
Replace the gas valve and set it up according to the setting parameters	35
Replace the p.c.b.	36
Replace the boiler thermostat/potentiometer	37
Fill and vent the system and the boiler	38
Insert the NTC sensor in the pocket correctly	39

ACV provides details of training courses on the maintenance of BG 2000 burners

FILLING THE HOT WATER AND HEATING CIRCUITS



IMPORTANT
It is essential that the water tank is under pressure before the heating circuit is filled.

1. Fill the hot water circuit and pressurise it.
2. Fill the heating circuit - do not exceed a pressure of 2 bar.
3. Vent the air in the top of the boiler.
4. Once you have vented the system, return the pressure to static pressure plus 0.5 bar.

Height of the heating system:

- 10 m ⇒ heating circuit pressure = 1.5 bar
- 15 m ⇒ heating circuit pressure = 2 bar

USING THE BOILER FOR THE FIRST TIME

1. Check the gas supply connection and ensure that it is free from leaks.
2. Check the electrical connection to the boiler and the boiler room ventilation, and ensure that the flue gas discharge pipes and the burner chamber plate are properly gas tight.
3. Set the boiler thermostat or potentiometer to between 60 and 90°C.
4. Move the Summer/Winter switch to the required position.
5. Move the main switch to "ON".
6. Carry out the necessary venting operations, measurements and settings.

RECOMMENDATION

ACV recommends that you have the boiler serviced at least once a year. Boiler servicing and checking must be carried out by a qualified engineer.

BOILER MAINTENANCE (refer to Figs. 1 and 2 on Page 4)

1. Isolate the boiler from the electrical supply at the switch on the external control box, and close the gas supply valve.
2. Move the main switch on the control panel to "OFF".
3. Remove the boiler cover (2) and dismantle the upper section of the chimney reducer (3).
4. Remove the baffles (24) from the flue ways (23) and clean them. Replace these items if worn.
5. Remove the burner cover and burner.
6. Brush the flue ways (23).
7. Clean the combustion chamber (20) and the burner.
8. Check the condition of the seal on the burner chamber plate.

MAINTENANCE OF SAFETY EQUIPMENT

- Check that all thermostats and safety devices operate correctly: boiler thermostat/potentiometer, thermal reset high limit thermostat and manual reset high limit thermostat.
- Check the safety valves in both the heating circuit and the hot water circuit.

DRAINING THE BOILER



The water draining from the drain cock is very hot and can cause serious burns. Keep all persons away from running hot water.

Draining the heating circuit (refer to Fig. 8 on Page 8)

1. Move the main switch on the control panel to "OFF", isolate the boiler from the electrical supply at the switch on the external control box and close the gas supply valve.
2. Close the isolating valves (8) in the heating circuit.
3. Connect a flexible tube to the drain cock (9).
4. Open the drain cock (9) to drain the heating circuit.

Draining the hot water circuit (refer to Fig. 9 on Page 8)

1. Move the main switch on the control panel to "OFF", isolate the boiler from the electrical supply at the switch on the external control box and close the gas supply valve.
2. Release the pressure in the heating circuit until the pressure gauge reads zero.
3. Close the tap (7) and the isolating valve (11).
4. Open the drain cock (9) and air vent (10) (first 9 then 10).
5. Allow the hot water circuit to discharge to the drain.



The drain cock (9) must be at ground level for the circuit to drain fully.

USE OF THE BOILER



We recommend that you have your system serviced each year by a qualified engineer.

Starting the burner:
In normal operation the burner starts automatically if the temperature of the boiler is below setpoint.



Before carrying out any work on the boiler, isolate it from the electrical supply at the switch on the external control box. Also move the main switch on the control panel to "OFF".

You should familiarise yourself with the control panel (Fig. 25)



The user must not attempt to gain access to the components inside the control panel.

1. Control thermostat (SV) or potentiometer (MV)

If the boiler is being used to generate hot water only, the boiler temperature can be set to between 60 and 90°C. If the boiler is being used for hot water and heating, then the boiler's control thermostat or its potentiometer should normally be set to 80°C to guarantee optimum operating conditions.

2. Main switch

This switch is used to start and stop the boiler

3. Summer/Winter switch

This switch is used to start and stop the heating pump (if a pump is fitted).

4. Thermometer

The thermometer shows the boiler temperature in the heating circuit. This temperature should not exceed 90°C. If it does, stop the boiler and check the settings on the thermostat (SV) or potentiometer (MV). If the problem persists, contact your installer for advice.

5. Resetting the burner

This switch can be used to restart the burner if it has shut down.

6. Burner indicator lamp

This lamp tells the user whether the burner has shut down (lamp on) or not (lamp off).

7. Controller (optional)

Refer to the instructions supplied with the controller if you have this option.

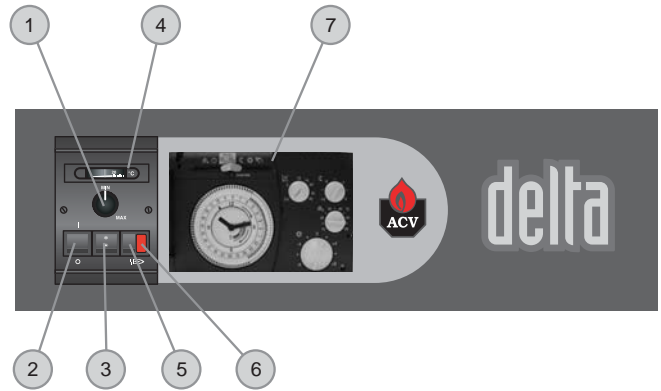

Fig. 25: Control panel

Gauge pressure in the heating system

Your system must be equipped with a heating safety valve calibrated to 3 bar and fitted with a pressure gauge.

Ensure that the system is always under water pressure. When the system is cold and the air inside it has been vented, the gauge must indicate a pressure between 0.5 and 1.5 bar depending on the height of the building.

To add water: (refer to Fig. 8 on Page 8)

- Open the filling valve (5).
- Close the valve properly after filling.
- Vent the system in order to obtain an accurate reading of the pressure inside the heating circuit.

Safety valves (heating circuit)

If water is found to be escaping from one of the safety valves, stop the boiler and contact your installer for advice.

A monthly test is recommended: Lift the lever on the drain cock for a few seconds to ensure that the safety valve is working correctly.



If there is a problem after this short test, please contact your installer for advice.

Safety group (hot water circuit)

A monthly test is recommended: Lift the lever on the drain cock for a few seconds to ensure that the safety group is working correctly.



If there is a problem after this short test, please contact your installer for advice.



Water escaping from the safety valve or safety group can be extremely hot and cause very serious burns.

USER GUIDE

BURNER SHUTDOWN

If the burner is not working:

1. The burner indicator lamp lights up on the control panel.
2. Press the burner reset button on the control panel. Now switch off the boiler for a few seconds at the main switch and then restart it.



If the burner does not operate, isolate the boiler's electrical supply at the switch on the external control box before removing the front panel of the casing.

3. Reset the manual reset high limit thermostat on the top of the boiler.

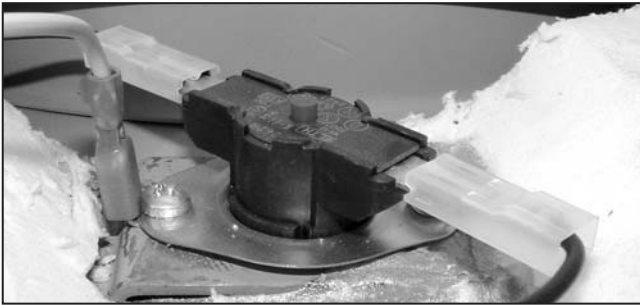

Wait until the boiler temperature has fallen to below 60°C, then refit the front panel of the casing.

5. If the problem persists, please contact your installer for advice.

Starting the burner.

In normal operation the burner starts automatically if the temperature of the boiler is below setpoint.



To ensure that your system operates correctly, please have it serviced annually by a qualified engineer; servicing should be done before the start of the heating season.

N°	Casing	Codes	
		Delta SV/MV - 35	Delta SV/MV - 50
A01	Body shell	30537389	30537227
A02	Front panel	21473397	21473398
A03	Left-hand side panel	21472397	21472398
A04	Right-hand side panel	21471397	21471398
A05	Rear panel	21474397	21474398
A06	Large top cover	21475397	21475397
A07	Small top cover	21478397	21478398
A08	Burner cover	21476397	21476397
A09	Control panel	21477342	21477342

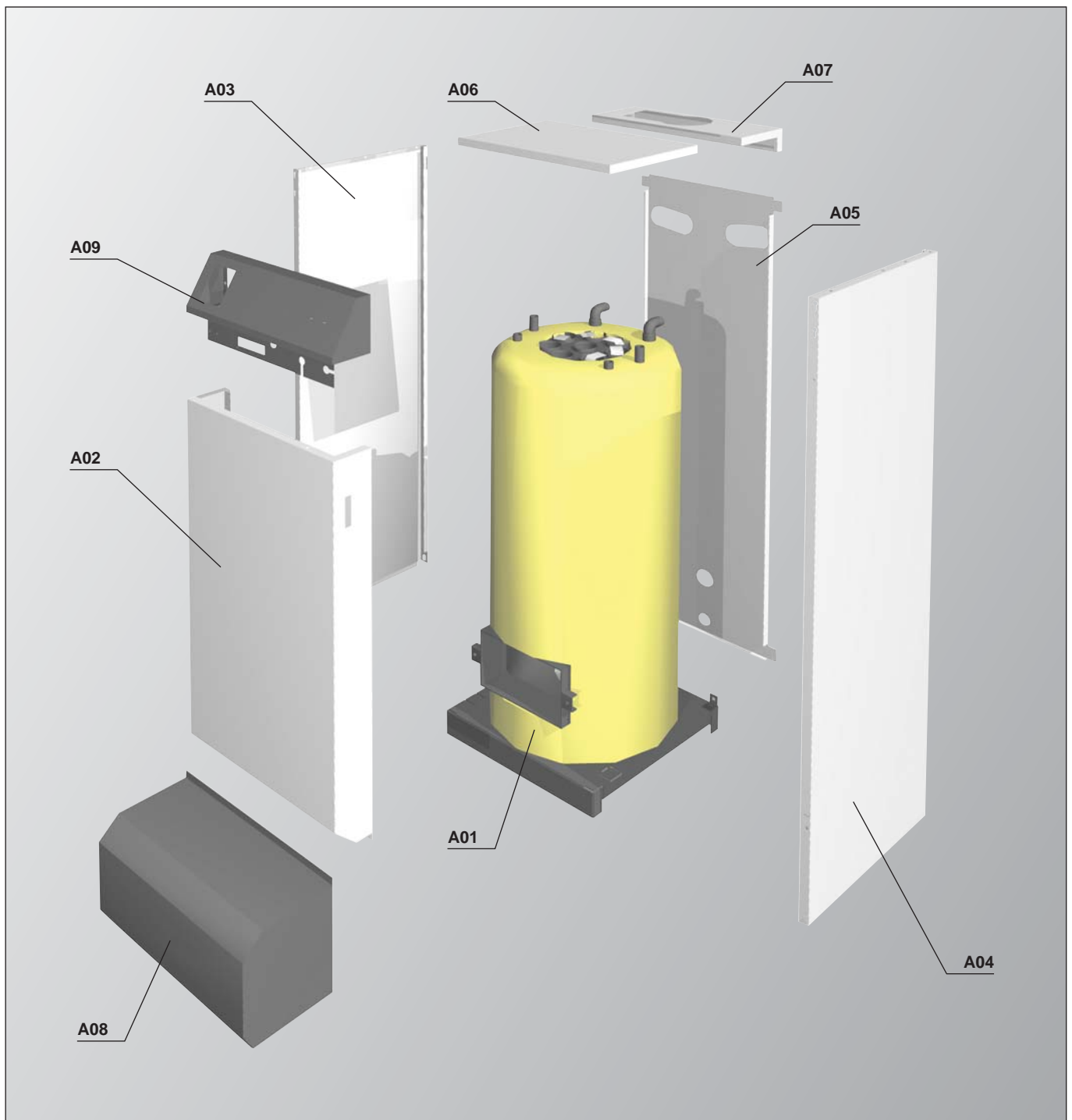

SPARE PARTS

Codes

N°	Accessories	SV 35	SV 50	MV 35	MV 50
B01	Complet control panel	24614063	24614063	24614065	24614065
B02	Test panel (SV)	54761004	54761004	-	-
B03	Test panel (MV)	-	-	54761005	54761005
B04	Summer/Winter switch	54766007	54766007	54766007	54766007
B05	Thermal reset high limit thermostat (95°C)	54322000	54322000	54322000	54322000
B06	Manual reset high limit thermostat (103°C)	54764010	54764010	54764010	54764010
B07	6-pin link (T1-T2)	257F1026	257F1026	257F1026	257F1026
B08	NTC sensor 12kOhm	-	-	547D3018	547D3018
	PVCC Plunger Ø 19.5 mm / L. 800 mm	49410045	-	49410045	-
B09	PVCC Plunger Ø 19.5 mm / L. 1000 mm	-	49410039	-	49410039
B10	Brass pocket Ø 1/2" / L. 100 mm	63438001	63438001	63438001	63438001
B11	Upper turbulator Type A	507F2009	507F2009	507F2009	507F2009
B12	Lower turbulator Type B	507F2010	507F2010	507F2010	507F2010
B13	Chimney reducer	507F3037	507F3042	507F3037	507F3042
	Balanced flue adapter Ø 80/125 mm	507F3038	-	507F3038	-
B14	Balanced flue adapter Ø 100/150 mm	-	507F3043	-	507F3043
B15	"Cérablanket" insulation	51305000	51305000	51305000	51305000
B16	Master-Neo tube Ø 80 / L. 2 m	537D6137	537D6137	537D6137	537D6137
B17	Drain cock Ø 1/2"	55426001	55426001	55426001	55426001
B18	Chimney reducer seal Ø 325	557A0016	557A0016	557A0016	557A0016
	Rubber seal Ø 80	557D2003	-	557D2003	-
B19	Rubber seal Ø 100	-	557A0049	-	557A0049
B20	Bend 90° Ø 50 mm	537D6090	537D6090	537D6090	537D6090
B21	Plastic reducer Ø 80/50 mm	537D6092	537D6092	537D6092	537D6092
B22	Clip retainer	47405004	47405004	47405004	47405004
B23	Clip stud	47405005	47405005	47405005	47405005
B24	Plastic reducer Ø 100/80 mm	-	537D6172	-	537D6172

Codes

N°	Burner BG 2000	SV 35	SV 50	MV 35	MV 50
B25	NIT tube	537DZ017	537DZ017	537DZ017	537DZ017
B26	Ignition electrode (bent)	537DX016	537DX016	537DX016	537DX016
B27	Ionisation electrode (bent)	537DX010	537DX010	537DX010	537DX010
B28	Ignition cable	537D5000	537D5000	537D5000	537D5000
B29	Ionisation cable	537D5001	537D5001	537D5001	537D5001
	Venturi VF002	537D4034	-	537D4034	-
B30	Venturi VF051	-	537D4028	-	537D4028
B31	Gas valve	537D4009	537D4009	537D4009	537D4009
B32	Control/monitoring relay	54768005	54768005	54768005	54768005
B33	Ceramic fibre cord	51700025	51700025	51700025	51700025
B34	Burner chamber plate insulation	51401049	51401049	51401049	51401049
B35	Flame inspection window + glass	50423365	50423365	50423365	50423365
B36	Gas valve flange Ø 1/2" + accessories	53402088	53402088	53402088	53402088
	Orifice 52 (propane)	537D4020	-	537D4020	-
B37	Orifice 68 (propane)	-	537D4037	-	537D4037
B38	Pressure tapping	53437039	53437039	53437039	53437039
B39	Circular seal (flame inspection window)	55412000	55412000	55412000	55412000
B40	Fan/door seal	55700026	55700026	55700026	55700026
B41	Tube seal Ø 107 x 1 mm	55700028	55700028	55700028	55700028
B42	Ignition electrode seal	557A0012	557A0012	557A0012	557A0012
B43	Ionisation electrode seal	55437034	55437034	55437034	55437034
B44	Venturi cork seal	557A0026	557A0026	557A0026	557A0026
B45	Venturi O-ring	557D6039	557D6039	557D6039	557D6039
B46	Fan + potentiometer	537D3008	537D3008	-	-
B47	Fan	-	-	537D3027	537D3027
B48	P.c.b. box	-	-	2147B263	2147B263
B49	Box cover	-	-	2147C263	2147C263
B50	Box + p.c.b. + wiring	-	-	5476G012	5476G013
B51	Burner wiring for BG 2000-SV	25760042	25760042	-	-
B52	Burner BG 2000-SV	237D0096	237D0102	-	-
B53	Burner BG 2000-MV	-	-	237D0098	237D0104

SPARE PARTS



B01

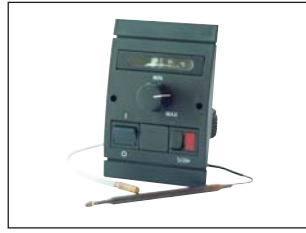

B02



B03



B04

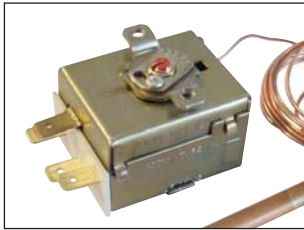

B05



B06

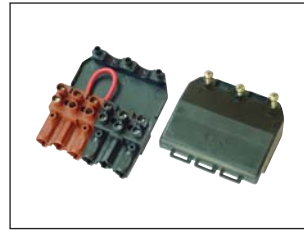

B07

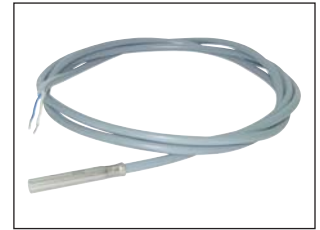

B08



B09



B10

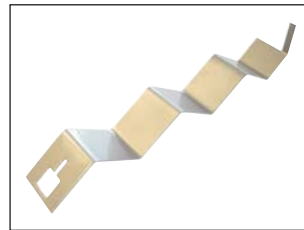

B11

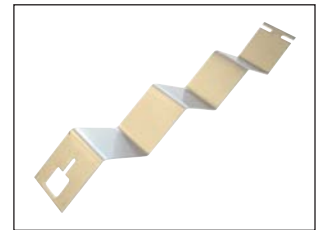

B12



B13



B14



B15



B16



B17



B18

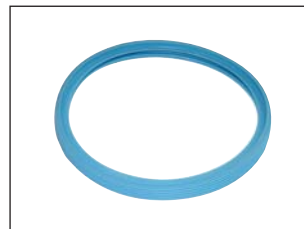

B19



20



B21



B22



B23



B24

SPARE PARTS

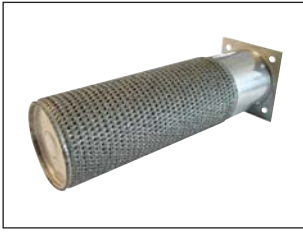

B25



B26

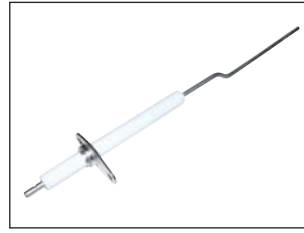

B27

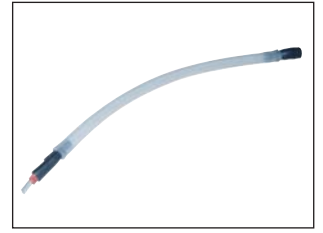

B28

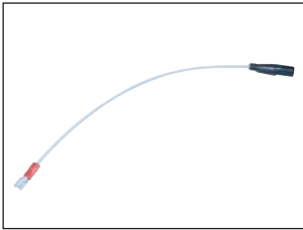

B29



B30

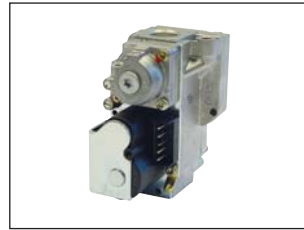

B31



B32



B33

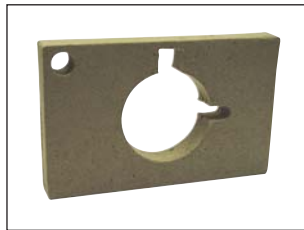

B34



B35



B36



B37



B38



B39



B40



B41



B42



B43



B44

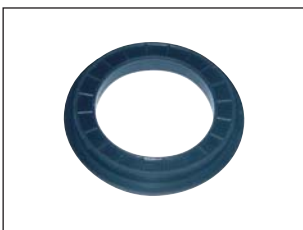

B45



B46



B47



B48

SPARE PARTS

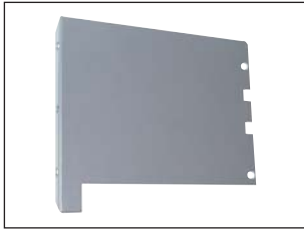

B49

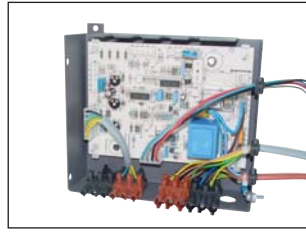

B50

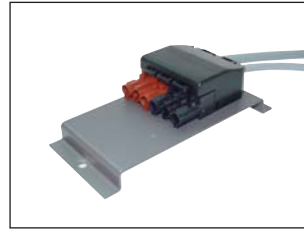

B51

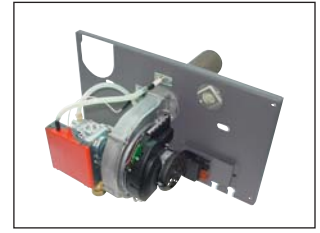

B52

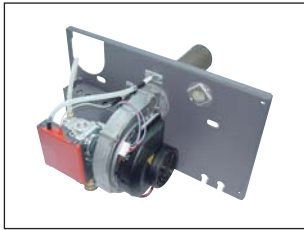

B53

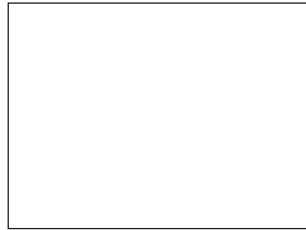

-

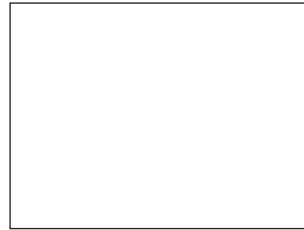

-

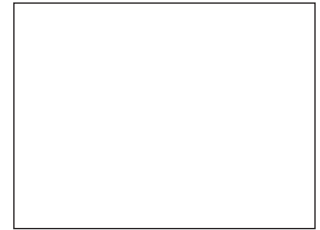

-

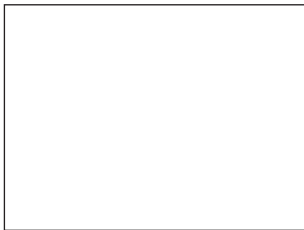

-

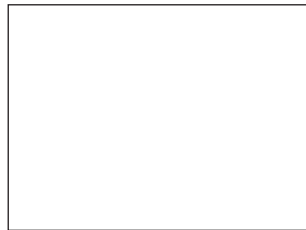

-

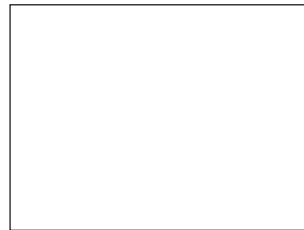

-

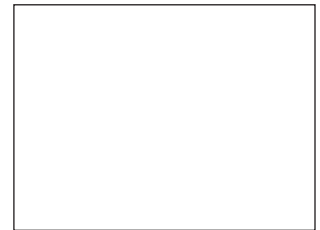

-



-



-



-



-



-



-



-



-



-



-



-



-

DETAILS OF THE INSTALLATION

Installation date: _____	Flue gas T°: _____	Model: _____
% CO ₂ (min. load): _____	Efficiency: _____	Serial number: _____
% CO ₂ (max. load): _____	Gas pressure: _____	Heating system pressure setting: _____
<input type="checkbox"/> Gas _____		
<input type="checkbox"/> Propane _____	Name and signature: _____	

SERVICE NOTES

Service date: _____	Flue gas T°: _____	Comments: _____
% CO ₂ (min. load): _____	Efficiency: _____	_____
% CO ₂ (max. load): _____	Gas pressure: _____	_____
<input type="checkbox"/> Gas _____		
<input type="checkbox"/> Propane _____	Name and signature: _____	

Service date: _____	Flue gas T°: _____	Comments: _____
% CO ₂ (min. load): _____	Efficiency: _____	_____
% CO ₂ (max. load): _____	Gas pressure: _____	_____
<input type="checkbox"/> Gas _____		
<input type="checkbox"/> Propane _____	Name and signature: _____	

Service date: _____	Flue gas T°: _____	Comments: _____
% CO ₂ (min. load): _____	Efficiency: _____	_____
% CO ₂ (max. load): _____	Gas pressure: _____	_____
<input type="checkbox"/> Gas _____		
<input type="checkbox"/> Propane _____	Name and signature: _____	

Service date: _____	Flue gas T°: _____	Comments: _____
% CO ₂ (min. load): _____	Efficiency: _____	_____
% CO ₂ (max. load): _____	Gas pressure: _____	_____
<input type="checkbox"/> Gas _____		
<input type="checkbox"/> Propane _____	Name and signature: _____	

Service date: _____	Flue gas T°: _____	Comments: _____
% CO ₂ (min. load): _____	Efficiency: _____	_____
% CO ₂ (max. load): _____	Gas pressure: _____	_____
<input type="checkbox"/> Gas _____		
<input type="checkbox"/> Propane _____	Name and signature: _____	

SERVICE RECORD

Service date:	Flue gas T°:	Comments:
% CO ₂ (min. load):	Efficiency:	
% CO ₂ (max. load):	Gas pressure:	
<input type="checkbox"/> Gas		
<input type="checkbox"/> Propane	Name and signature:	

Service date:	Flue gas T°:	Comments:
% CO ₂ (min. load):	Efficiency:	
% CO ₂ (max. load):	Gas pressure:	
<input type="checkbox"/> Gas		
<input type="checkbox"/> Propane	Name and signature:	

Service date:	Flue gas T°:	Comments:
% CO ₂ (min. load):	Efficiency:	
% CO ₂ (max. load):	Gas pressure:	
<input type="checkbox"/> Gas		
<input type="checkbox"/> Propane	Name and signature:	

Service date:	Flue gas T°:	Comments:
% CO ₂ (min. load):	Efficiency:	
% CO ₂ (max. load):	Gas pressure:	
<input type="checkbox"/> Gas		
<input type="checkbox"/> Propane	Name and signature:	

Service date:	Flue gas T°:	Comments:
% CO ₂ (min. load):	Efficiency:	
% CO ₂ (max. load):	Gas pressure:	
<input type="checkbox"/> Gas		
<input type="checkbox"/> Propane	Name and signature:	

Service date:	Flue gas T°:	Comments:
% CO ₂ (min. load):	Efficiency:	
% CO ₂ (max. load):	Gas pressure:	
<input type="checkbox"/> Gas		
<input type="checkbox"/> Propane	Name and signature:	

Service date:	Flue gas T°:	Comments:
% CO ₂ (min. load):	Efficiency:	
% CO ₂ (max. load):	Gas pressure:	
<input type="checkbox"/> Gas		
<input type="checkbox"/> Propane	Name and signature:	

Service date:	Flue gas T°:	Comments:
% CO ₂ (min. load):	Efficiency:	
% CO ₂ (max. load):	Gas pressure:	
<input type="checkbox"/> Gas		
<input type="checkbox"/> Propane	Name and signature:	

Service date:	Flue gas T°:	Comments:
% CO ₂ (min. load):	Efficiency:	
% CO ₂ (max. load):	Gas pressure:	
<input type="checkbox"/> Gas		
<input type="checkbox"/> Propane	Name and signature:	

Service date:	Flue gas T°:	Comments:
% CO ₂ (min. load):	Efficiency:	
% CO ₂ (max. load):	Gas pressure:	
<input type="checkbox"/> Gas		
<input type="checkbox"/> Propane	Name and signature:	

Service date:	Flue gas T°:	Comments:
% CO ₂ (min. load):	Efficiency:	
% CO ₂ (max. load):	Gas pressure:	
<input type="checkbox"/> Gas		
<input type="checkbox"/> Propane	Name and signature:	

Service date:	Flue gas T°:	Comments:
% CO ₂ (min. load):	Efficiency:	
% CO ₂ (max. load):	Gas pressure:	
<input type="checkbox"/> Gas		
<input type="checkbox"/> Propane	Name and signature:	

SERVICE RECORD

Service date:	Flue gas T°:	Comments:
% CO ₂ (min. load):	Efficiency:	
% CO ₂ (max. load):	Gas pressure:	
<input type="checkbox"/> Gas		
<input type="checkbox"/> Propane	Name and signature:	

Service date:	Flue gas T°:	Comments:
% CO ₂ (min. load):	Efficiency:	
% CO ₂ (max. load):	Gas pressure:	
<input type="checkbox"/> Gas		
<input type="checkbox"/> Propane	Name and signature:	

Service date:	Flue gas T°:	Comments:
% CO ₂ (min. load):	Efficiency:	
% CO ₂ (max. load):	Gas pressure:	
<input type="checkbox"/> Gas		
<input type="checkbox"/> Propane	Name and signature:	

Service date:	Flue gas T°:	Comments:
% CO ₂ (min. load):	Efficiency:	
% CO ₂ (max. load):	Gas pressure:	
<input type="checkbox"/> Gas		
<input type="checkbox"/> Propane	Name and signature:	

Service date:	Flue gas T°:	Comments:
% CO ₂ (min. load):	Efficiency:	
% CO ₂ (max. load):	Gas pressure:	
<input type="checkbox"/> Gas		
<input type="checkbox"/> Propane	Name and signature:	

Service date:	Flue gas T°:	Comments:
% CO ₂ (min. load):	Efficiency:	
% CO ₂ (max. load):	Gas pressure:	
<input type="checkbox"/> Gas		
<input type="checkbox"/> Propane	Name and signature:	





excellence in hot water

www.acv-world.com

INTERNATIONAL

ACV international n.v
KERKPLEIN, 39
B-1601 RUISBROEK - BELGIUM
TEL.: +32 2 334 82 20
FAX: +32 2 378 16 49
E-MAIL: international.info@acv-world.com

BELGIUM

ACV BELGIUM nv/sa
KERKPLEIN, 39
B-1601 RUISBROEK-BELGIUM
TEL.: +32 2 334 82 40
FAX: +32 2 334 82 59
E-MAIL: belgium.info@acv-world.com

CHILE

ALBIN TROTTER Y ACV LTDA
SAN PABLO 3800
QUINTA NORMAL - SANTIAGO - CHILE
TEL.: +56 2 772 01 69
FAX: +56 2 772 92 62/63
E-MAIL: chile.info@acv-world.com

CZECH REPUBLIC

ACV CR SPOL. s.r.o
NA KRECKU 365
CR-109 04 PRAHA 10 - CZECH REPUBLIC
TEL.: +420 2 720 83 341
FAX: +420 2 720 83 343
E-MAIL: ceskarepublika.info@acv-world.com

DEUTSCHLAND

ACV WÄRMETECHNIK GMBH & CO KG
GEWERBEGEBIET GARTENSTRASSE
D-08132 MÜLSEN OT ST. JACOB - DEUTSCHLAND
TEL.: +49 37601 311 30
FAX: +49 37601 311 31
E-MAIL: deutschland.info@acv-world.com

ESPAÑA

ACV ESPAÑA
C/DE LA TEIXIDORA, 76
POL. IND. LES HORTES
E-08302 MATARÓ - ESPAÑA
TEL.: +34 93 759 54 51
FAX: +34 93 759 34 98
E-MAIL: spain.info@acv-world.com

ARGENTINA

TECNO PRACTICA
ALFEREZ BOUCHARD 4857
1605 CARAPACHAY - BUENOS AIRES
TEL.: +54 11 47 65 33 35
FAX: +54 11 47 65 43 07
E-MAIL: jchas@tecnopractica.com

AUSTRALIA

HUNT HEATING PTY LTD
10 GARDEN BOULEVARD
3172 VICTORIA - AUSTRALIA
TEL.: +61 3 9558 7077
FAX: +61 3 9558 7027
E-MAIL: enquiries@hunheat.com.au

BRAZIL

SIMETAL INDUSTRIA E COMERCIO DE FERRAMENTAS LTDA
RUA GERSON ANDREIS 535
95112 - 130 CAXIAS DO SUL - BRAZIL
TEL.: +55 54 227 12 44
FAX: +55 54 227 12 26
E-MAIL: export@simetall.com.br

BULGARIA

PROXIMUS ENGINEERING LTD
7 BIAL KREM STR.
9010 VARNNA - BULGARIA
TEL.: +359 52 500 070
FAX: +359 52 301 131
E-MAIL: info@proximus-bg.com

CHINA

BEIJING HUADIAN HT POWER TECHNOLOGY DEVELOPMENT CO. LTD
ROOM B-912, TOWER B, COFCO PLAZA
Nº. 8, JIANGUOMENNEI AVENUE
BEIJING 100005 - PEOPLE'S REPUBLIC OF CHINA
TEL.: +86 10 652 30 363/393 EXT 101
FAX: +86 10 652 27 071
E-MAIL: li.zheng@acv-world.com

SHANGHAI COOLTECH LTD

14/F E. CHINA MERCHANTS PLAZA
Nº. 333 CHENGDU ROAD (N)
200041 SHANGHAI - CHINA
TEL.: +86 21 52 98 11 22 - 820
FAX: +86 21 52 98 13 58
E-MAIL: cooltech@cooltech.sh.cn

FRANCE

ACV FRANCE sa
31, RUE AMPERE - Z.I MI - PLAINE
F-69680 CHASSIEU - FRANCE
TEL.: +33 4 72 47 07 76
FAX: +33 4 72 47 08 72
E-MAIL: france.info@acv-world.com

ITALIA

ACV ITALIA
VIA PANA 92
I-48018 FAENZA (RA) - ITALIA
TEL.: +39 0546 64 61 44
FAX: +39 0546 64 61 50
E-MAIL: italia.info@acv-world.com

NEDERLAND

ACV NEDERLAND bv
POSTBUS 350
NL-2980 AJ RIDDERKERK - NEDERLAND
TEL.: +31 180 42 10 55
FAX: +31 180 41 58 02
E-MAIL: nederland.info@acv-world.com

POLAND

ACV POLSKA sp. z o.o.
UL. WITOSA 3
87 - 800 WŁOCŁAWEK - POLAND
TEL.: +48 54 412 56 00
FAX: +48 54 412 56 01
E-MAIL: polska.info@acv-world.com

PORTUGAL

BOILERNOX LDA
RUA OUTEIRO DO POMAR
CASAL DO CEGO, FRACÇÃO C,
PAVILHÃO 3 - MARRAZES
2400-402 LEIRIA - PORTUGAL
TEL.: +351 244 837 239/40
FAX: +351 244 823 758
E-MAIL: boilernox@mail.telepac.pt

RUSSIA

ACV RUSSIA
1/9, MALYI KISELNYI
103031 MOSCOW - RUSSIA
TEL.: +7 095 928 48 02 / +7 095 921 89 79
FAX: +7 095 928 08 77
E-MAIL: russia.info@acv-world.com

DENMARK

VARMEHUSET
FRICHSVEJ 40 A
8600 SILKEBORG - DENMARK
TEL.: +45 86 82 63 55
FAX: +45 86 82 65 03
E-MAIL: vh@varmehuset.dk

ESTONIA

TERMOMX AS
TAHE 112A
51013 TARTU - ESTONIA
TEL.: +372 736 73 39
FAX: +372 736 73 44
E-MAIL: termomx@termomx.ee

GREECE

ESTIAS
MARASLI STREET 7
54248 THESSALONIKI - GREECE
TEL.: +30 23 10 31 98 77 / +30 23 10 32 03 58
FAX: +30 23 10 31 97 22
E-MAIL: info@genikithermanseon.gr

ÎLE MAURICE

SOTRATECH
29, RUE MELDRUM
BEAU BASSIN - ÎLE MAURICE
TEL.: +230 46 76 970
FAX: +230 46 76 971
E-MAIL: stech@intnet.mu

LITHUANIA

UAB "GILIUS IR KO"
SAVARNORIŲ PR. 192
3000 KAUNAS - LITHUANIA
TEL.: +370 37 308 930
FAX: +370 37 308 932

MAROC

CASATHERM
PLACE EL YASSIR
20300 CASABLANCA - MAROC
TEL.: +212 22 40 15 23
FAX: +212 22 24 04 86

SLOVAK REPUBLIC

ACV SLOVAKIA s.r.o.
PLUHOVÁ 49
831 04 BRATISLAVA - SLOVAK REPUBLIC
TEL.: +421 2 444 62 276
FAX: +421 2 444 62 275
E-MAIL: slovakia.info@acv-world.com

SLOVENIA

ACV D.O.O. SLOVENIA
OPEKARNA 22b
1420 TRBOVLJE - SLOVENIA
TEL.: +386 356 32 830
FAX: +386 356 32 831
E-MAIL: slovenia.info@acv-world.com

UK

ACV UK Ltd
ST. DAVID'S BUSINESS PARK
DALGETY BAY - FIFE - KY11 9PF
TEL.: +44 1383 82 01 00
FAX: +44 1383 82 01 80
E-MAIL: uk.info@acv-world.com

USA

TRIANGLE TUBE PHASE III
FREEWAY CENTER - 1 TRIANGLE LANE
BLACKWOOD NJ 08012 - USA
TEL.: +1 856 228 8881
FAX: +1 856 228 3584
E-MAIL: sales@triangletube.com

NEW ZEALAND

ENERGY PRODUCTS INTERNATIONAL
8/10 BELFAST PLACE
PO BOX 15058 HAMILTON - NEW ZEALAND
TEL.: +64 7 847 27 05
FAX: +64 7 847 42 22
E-MAIL: pmckenzie@tycoint.com

ÖSTERREICH

PROTHERM HEIZUNGSTECHNIK GmbH
TRAUNFURSTRASSE 113
4052 ANSFELDEN - ÖSTERREICH
TEL.: +43 7229 804 82
FAX: +43 7229 804 92
E-MAIL: protherm@nextra.at

ROMANIA

SC TRUST EURO THERM SA
D.N PIATRA NEAMT - ROMAN
km 2 C.P 5 O.P 3 jud. Neamt
5600 PIATRA NEAMT - ROMANIA
TEL.: +40 233 20 62 06
FAX: +40 233 20 62 00
E-MAIL: office@eurotherm.ro

TUNISIE

SO.CO.ME CHAUMAX
BOÎTE POSTALE N°44
1002 TUNIS - TUNISIE
TEL.: +216 71 78 15 91
FAX: +216 71 78 87 31

UKRAINE

UKRTEPLOSERVICE LTD
PR. LAGUTENKO 14
83086 DONETSK - UKRAINE
TEL.: +38 062 382 60 47/48
FAX: +38 062 335 16 89